



SERVICE BULLETIN 00007

Date Released: February 4, 2021
Date Effective: February 4, 2021
Subject: Directions to Replace WD-1021 Landing Gear Mount
Affected Models: RV-10

Fuselage kits shipped before January 28, 2021

Required Action: Per Van's Aircraft service letter SL-00033, inspect the WD-1021 Landing Gear Mounts for cracks in the corner plate of the gear mounts, and for cracks propagating from the top, outboard attachment bolt hole (see Figure 1). The front seats and underlying F-1067B Seat Floor Covers must be removed for this inspection.

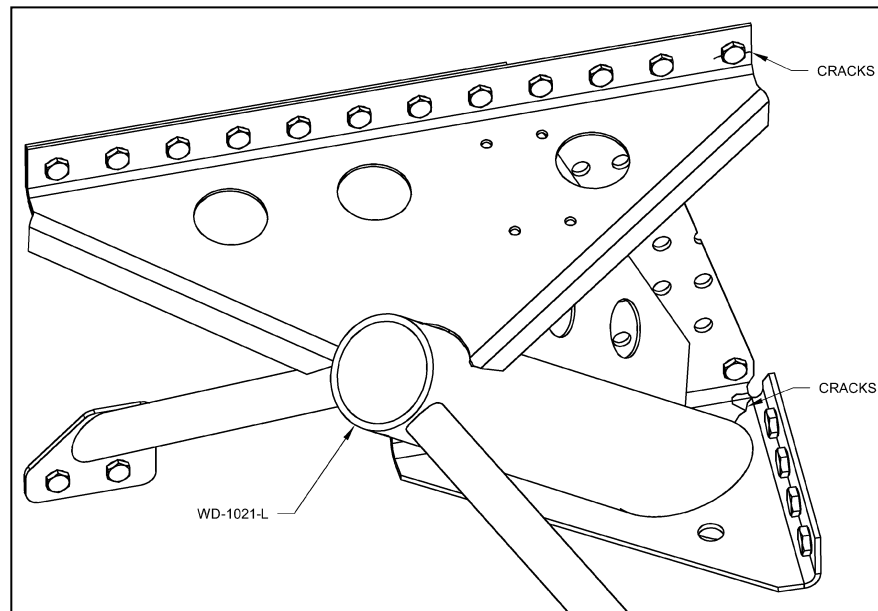

FIGURE 1: LANDING GEAR MOUNT CRACKS

In addition, double check the inspection in SL-00033. Inspect the F-1050 Forward Cabin Floor Panels for cracks propagating from the corners of the cut-outs for the landing gear mounts (see Figure 2). If cracks are discovered in the floor panel, stop-drill the cracks in the floor panels per the instructions in SL-00033.

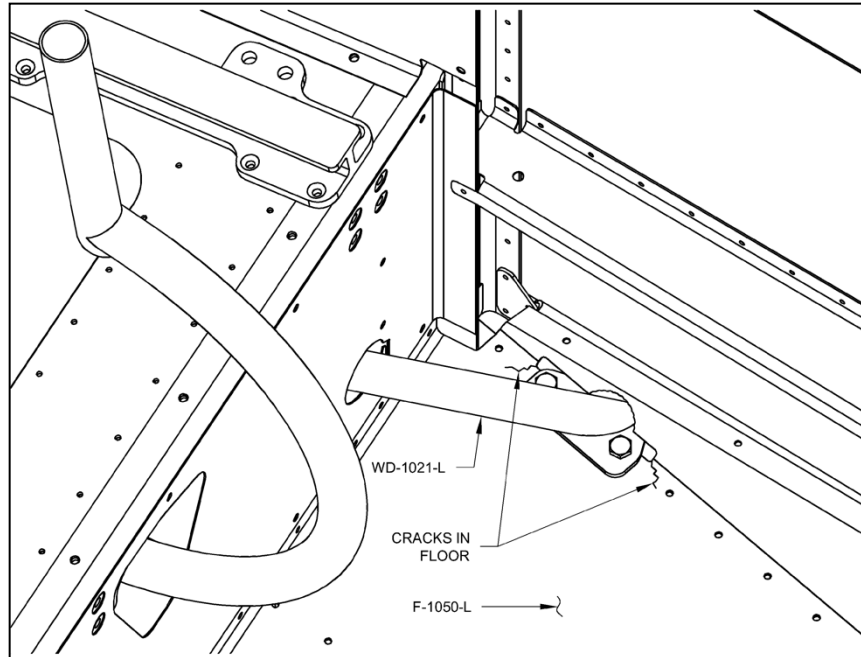

FIGURE 2: FLOOR PANEL CRACKS

Time of Compliance: At or before the next annual condition inspection

Labor Required: Up to 32 Hours

Level of Certification: Check the rules of the local controlling agency and the operating limitations for your aircraft

Synopsis:

This service information provides detailed instructions to owners that have reported cracks in their WD-1021 Landing Gear Mounts (see Figure 1) per SL-00033, and which have been reviewed and confirmed by Van's Aircraft's support team. Note that Van's Aircraft does not recommend replacing the WD-1021 parts on a completed airplane unless cracks are observed and confirmed through the support review process, and parts will be provided only if cracks are found.

Materials Required:

In the event the landing gear weldments are cracked and must therefore be replaced, the following materials are required to complete the steps necessary to achieve compliance with this Service Bulletin:

Purchase Part no. SB-00007 from Van's Aircraft. This kit contains all the parts needed to modify the existing structure and complete the replacement of the main gear weldments.

Purchase or obtain a low-profile angle drill and a 5/16" extra-length drill bit (e.g. MSC Part #: 88126172) to fit.

Optional: Purchase Part no. F-01043D-L-1 & -R-1 Cover Panel. Since the updated gear leg weldment design no longer includes the forward support arm, the clearance hole for the support arm has been removed from this version of the cover panel. The original panel with the clearance hole can still be used if desired.

Method of Compliance:

Step 1: Make or obtain a sawhorse approximately 32 inches tall and 48 inches wide that can safely hold 1600 pounds.

Step 2: Cut a 12-inch x 48-inch piece of plywood and wrap the top surface with a sheet of dense foam. (This will be placed between sawhorse and the bottom of the fuselage.)

Step 3: Position the aircraft in a location that will allow for wing removal.

Step 4: Remove loose items from the cabin and cargo areas.

Step 5: Drain the fuel from the wings.

Step 6: Remove the front seats, the F-1015D Mid Cabin Side Covers, F-1043D Cover Panel, F-1067B Seat Floor Cover, seats rails, and F-1067A Seat Floors. See KAI Sections 28, 35, and 49.

Step 7: Remove the WD-1012 Control Sticks from the WD-1011 Control Stick Bases. See KAI Section 39.

Step 8: Remove the U-1057A & B Wheel Fairings, U-1020 Upper Intersection Fairings, and U-1017A Gear Leg Fairings. See KAI Section 48.

Step 9: Remove the F-1099A & B Upper and Lower Wing Root Fairings and the W-1015 Wing Tips. See KAI Sections 24 and 44. (Removing the wing tips is not strictly necessary but will greatly reduce the risk of dropping a wing during removal by providing handholds through the tip rib lightening holes.)

Step 10: Remove the top engine cowl (KAI Section 47), then remove the cap from the VA-107 Brake Reservoir (KAI Section 38) and drain the brake fluid from the system. Low pressure compressed air injected into the reservoir with the bleeder valve open will help evacuate the fluid from the low points in the system.

Step 11: Remove the brake line and fuel line running forward of the WD-1021-L/R Landing Gear Mounts and remove the bulkhead fluid fitting (for the brake line) from the mounts. See KAI Page 36-2, Figures 1 and 2, and KAI Page 37-3, Figure 5.

Step 12: Within the gap between the wing and fuselage, disconnect the fuel supply lines at the fuel tank (KAI Section 44), wiring, and pitot line (KAI Section 20).

Step 13: Jack the aircraft using the wing jacking points. Place the sawhorse under the fuselage just forward of the rear spar carry-through bulkhead. Insert the foam-covered plywood between the sawhorse and fuselage, then carefully lower the aircraft onto the sawhorse. Chock the nose wheel.

Step 14: Within the gap between the wing and fuselage, disconnect the F-1064 Aileron Pushrod Assembly from the WD-1014 Torque Tube Assembly and disconnect the VA-256 Flap Pushrod Assembly from the WD-1013B Flap Horn. See KAI Section 44.

Step 15: Unbolt and remove the wings.

Step 16: Remove the main wheels from the U-1001 Main Gear Legs, then remove the main gear legs from the WD-1021 Landing Gear Mounts. See KAI Section 46.

Step 17: Unbolt and remove both landing gear mounts. See KAI Section 29.

Step 18: Drill out the two AN470AD4 rivets located in Figure 3 from both sides of the Forward Center Section Bulkhead Assembly. For techniques on drilling out rivets, see KAI Section 5.4, "REMOVING 'AN' RIVETS".

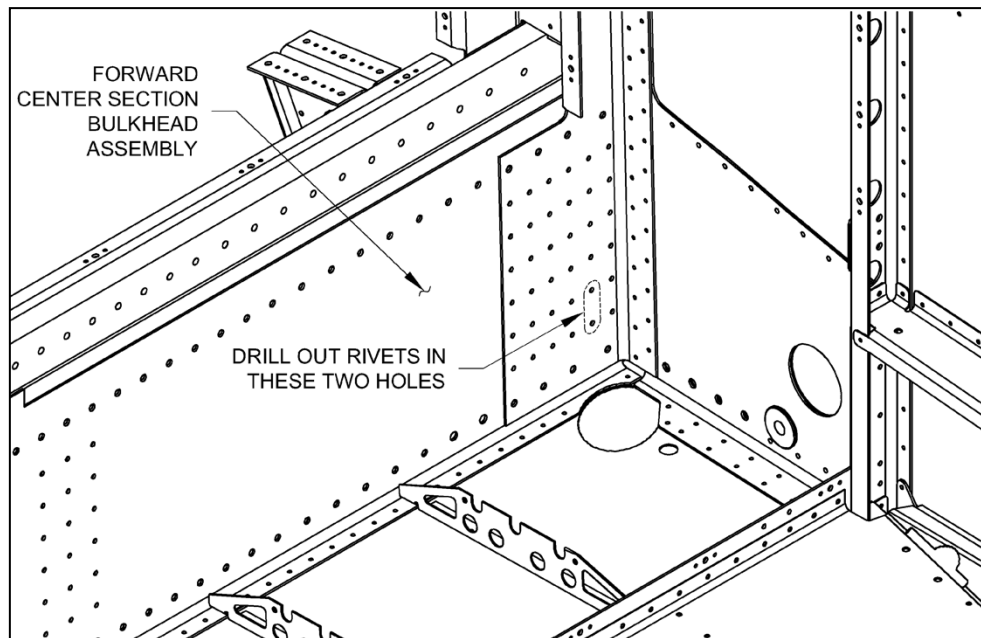

FIGURE 3: REMOVING RIVETS FROM BULKHEAD

Step 19: Position the VA-00274 and VA-00275 Drill Templates on the center section, over the holes for the left landing gear mount, and insert the three bolts shown in Figure 4. Secure the bolts with lightly tightened nuts.

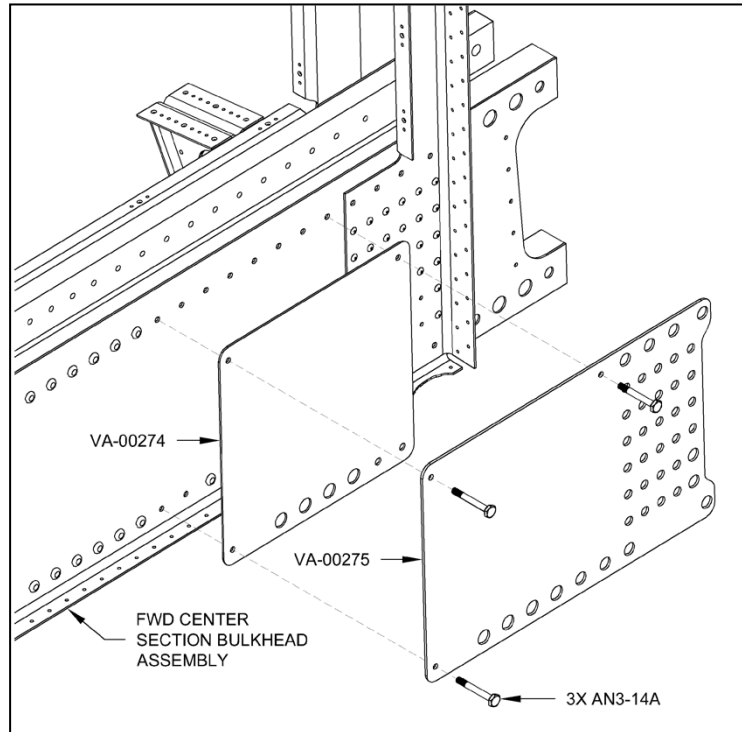

FIGURE 4: POSITIONING THE DRILL TEMPLATES

Step 20: Drill all of the .250-inch holes indicated in Figure 5 through the Forward Center Section Bulkhead Assembly. Insert the reduced diameter end of the VA-00272 Drill Bushing into the drill template hole. Hold the drill bushing firmly against the drill template, then, while keeping the drill bit perpendicular to the face of the bulkhead, drill the existing hole in the center section to .250. Use an angle drill where necessary. Insert an AN4 bolt as each hole is drilled.

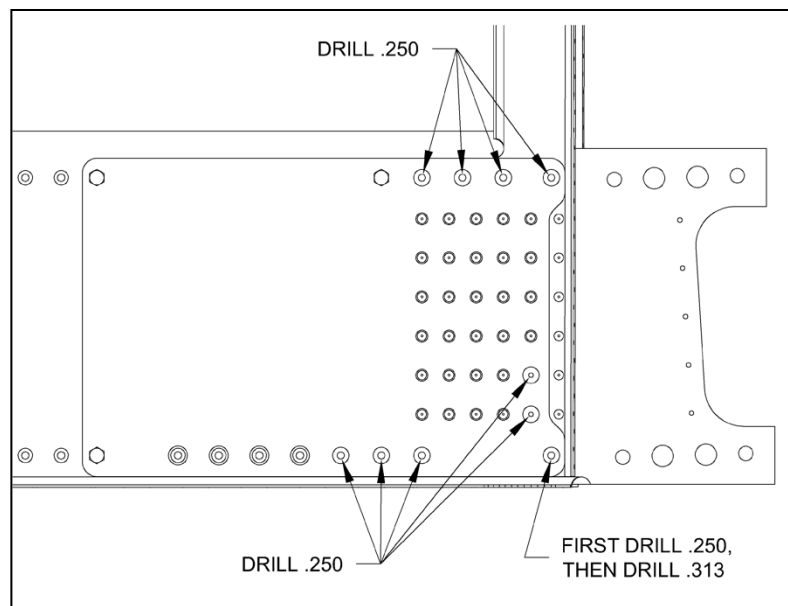

FIGURE 5: DRILLING THE FWD CENTER SECTION BULKHEAD ASSEMBLY

NOTE: To make drilling easier, grind flats on opposite sides of the drill bushing that will allow a 11/16 wrench to just slip on. End the grind roughly 75% down the length of the bushing so that the wrench, with the aid of a clamp, will hold the bushing against the bulkhead as shown in Figure 6. For the bottom holes, instead of the clamp, use a block of wood wedged between the wrench and the next bulkhead forward of this position, the F-1043A.

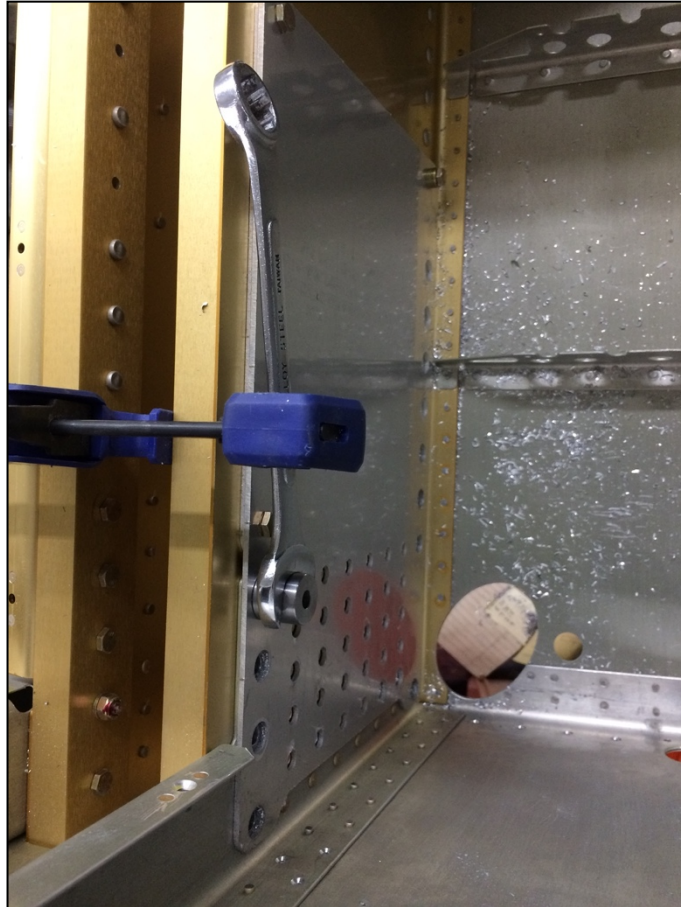

FIGURE 6: SECURING THE DRILL BUSHING

Step 21: After all the .250 holes have been drilled, insert the VA-00273 Drill Bushing into the bottom outboard hole (see Figure 5) in the drill template. Use an angle drill to drill the .250 hole up to .313. If the bit used with the angle drill is not long enough to drill entirely through the center section bar, after drilling as deep as possible with the drill bushing in place, remove the drill bushing and carefully finish the hole without it.

Step 22: Remove the drill templates, flip them over, and repeat Steps 19 through 21 for the right side of the center section.

Step 23: From both sides of the fuselage, drill out the AN470AD4 rivets that attach F-1099F Wing Root Fairing Support to the F-1069 Fwd Fuse Side Skin, then remove the support. See Figure 7.

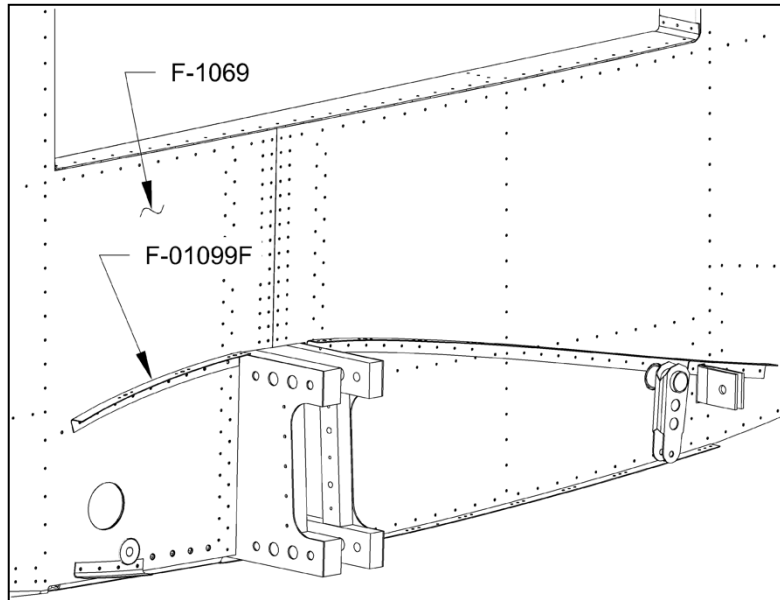

FIGURE 7: REMOVING THE WING ROOT FAIRING SUPPORT

Step 24: From both sides of the fuselage, drill out the three AN426AD3 rivets called out in Figure 8 that are used to attach the flange of the F-1004C Center Section Bulkhead to the side skin. Count the rivets from the bottom of the flange to be sure to identify the correct rivets.

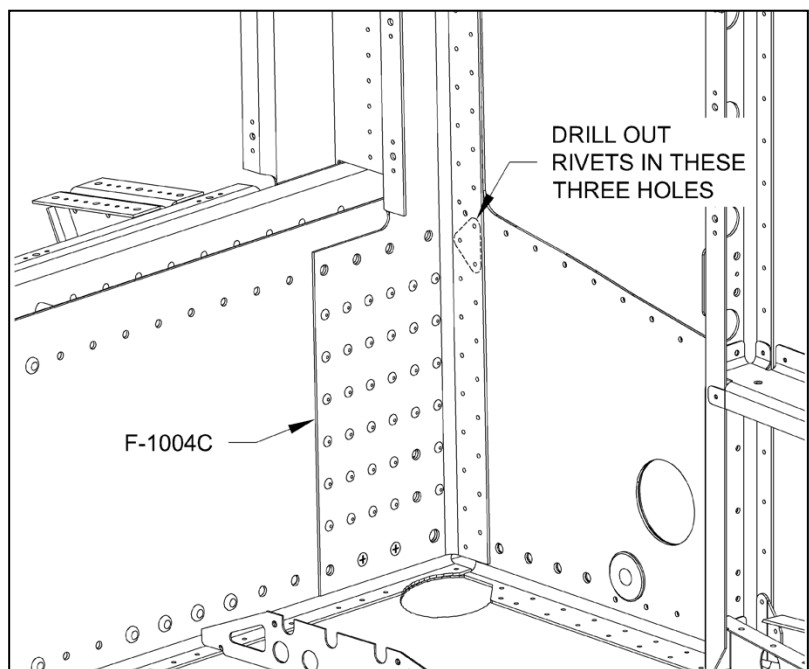

FIGURE 8: REMOVING FLANGE RIVETS

NOTE: The following steps and figures describe and depict the installation of the left landing gear mount. Repeat for the installation of the right landing gear mount.

Step 25: Machine-countersink for double flush rivets the three holes in the F-1004C Center Section Bulkhead from which the rivets were removed in the previous step. Reinstall double flush AN426AD3-4 rivets.

Step 26: Using the top three holes in the F-01004T-L Center Section Side Plate Doubler, cleco the doubler in place as shown in Figure 9.

FIGURE 9: CENTER SECTION SIDE PLATE DOUBLER

Step 27: Adjust the bottom of the side plate doubler to center, as closely as possible, the four #30 holes along the bottom edge with the \varnothing .188 holes in the F-1069 Fwd Fuse Side Skin.

Step 28: Match-Drill #30 all the remaining #30 holes of the side plate doubler through the F-1004K Center Section Side Plate and into the side skin. Support the skin with a wood block while drilling to minimize drill shaving entrapment between the parts. Cleco while progressing.

Step 29: Remove the side plate doubler and deburr.

NOTE: To enhance the reflectivity of the drill templates in the following steps, a piece of aluminum foil tape can be applied over the steel. The reflection of the drill bit will assist in keeping it perpendicular to the skin while drilling.

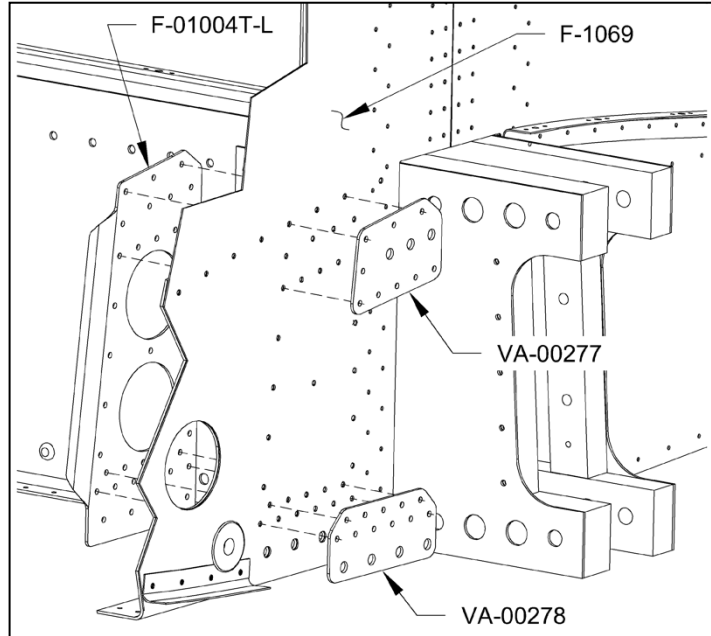

FIGURE 10: TOP AND BOTTOM DRILL TEMPLATES

Step 30: Cleco the side plate doubler back in place along with the VA-00277 and VA-00278 Top and Bottom Drill Templates as shown in Figure 10. (For correct orientation, notice on the bottom drill template that the aft $\text{\O}.$ 250 hole is closer to the edge than the forward $\text{\O}.$ 250 hole.) Cleco all the holes except the holes that correspond to the flanges of the landing gear mount (the holes within the $\text{\O}.$ 250 holes in the drill templates).

Step 31: Enlarge the hole in the bottom skin just enough to clear the bottom end of the new gear leg weldment socket (an additional $1/16$ " should be a good start), then bolt the gear leg weldments in place on the center section using the four bolts shown in Figure 11. Use a drilling lubricant such as 'Boelube' on the shank of the bolts to ease installation but be sure not to get any on the threads. Tighten the nuts to the correct installation torque.

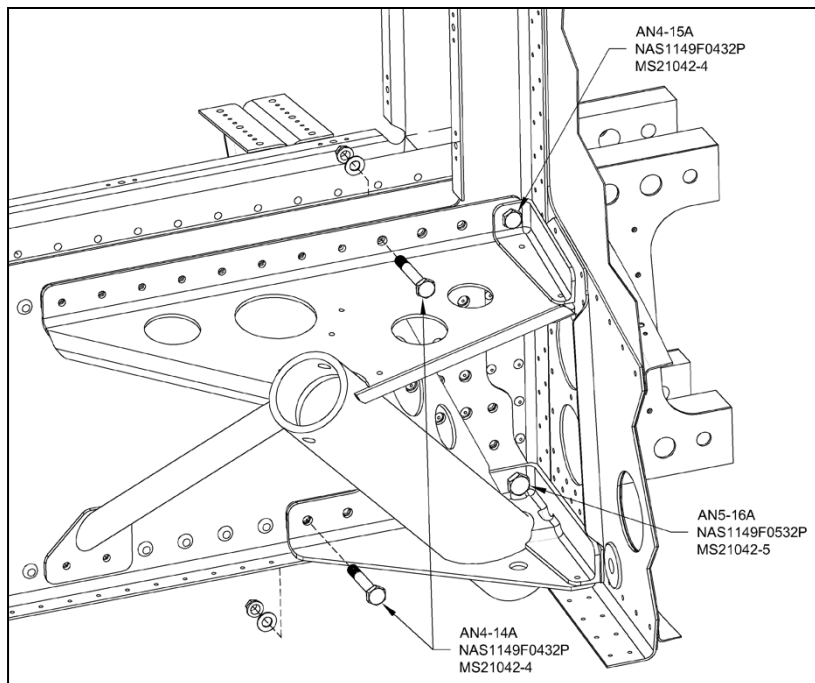

FIGURE 11: TEMP INSTALL THE GEAR LEG WELDMENT

Step 32: Match-Drill #30 the three #30 holes of the side skin (visible within the Ø.250 holes in the top drill template) into the top flange of the gear leg weldment. Be sure to keep the bit perpendicular to the side of the fuselage while drilling and use a drilling lubricant such as 'Boelube' when drilling steel.

Step 33: Match-Drill #30 the four #30 holes of the side plate doubler (visible within the Ø.250 holes in the bottom drill template) into the bottom flange of the gear leg weldment. Again, be sure to keep the bit perpendicular to the side of the fuselage while drilling and use a drilling lubricant.

Step 34: Final-Drill .250 one of the #30 holes (made in the previous step) in the bottom flange of the gear leg weldment using the hole in the bottom drill template as a guide. Be sure to keep the bit perpendicular to the side of the fuselage while drilling. Insert an AN4 bolt to maintain alignment.

Step 35: Repeat Step 34 for the remaining three holes.

Step 36: Final-Drill .250 one of the #30 holes in the top flange of the gear leg weldment using the hole in the top drill template as a guide. Insert an AN4 bolt after drilling each hole.

Step 37: Repeat Step 36 for the remaining two holes.

Step 38: Remove the drill templates.

Step 39: Remove the weldment and side plate doubler, deburr all the drilled holes, and prime the parts if desired.

Step 40: Cleco the side plate doubler and the F-1099F Wing Root Fairing Support back in place, then rivet all the holes in the wing root fairing support and all the holes in the side plate doubler using AN470AD4-6 rivets.

Step 41: Bolt the gear weldments in place along with the F-01057-L-1 & -R-1 Mid Seat Rail Supports as shown in Figure 12. Apply 'Boelube' to the shanks of the bolts (do not get any on the threads) and do not tighten any of the nuts until all of the bolts have been started in the carry through bars.

Add a shim between the flanges of the gear leg weldment and side plate doubler if a gap of .040 inches or more exists (use the VA-00277 and VA-00278 Drill Templates to drill the Ø.250 holes in the shim).

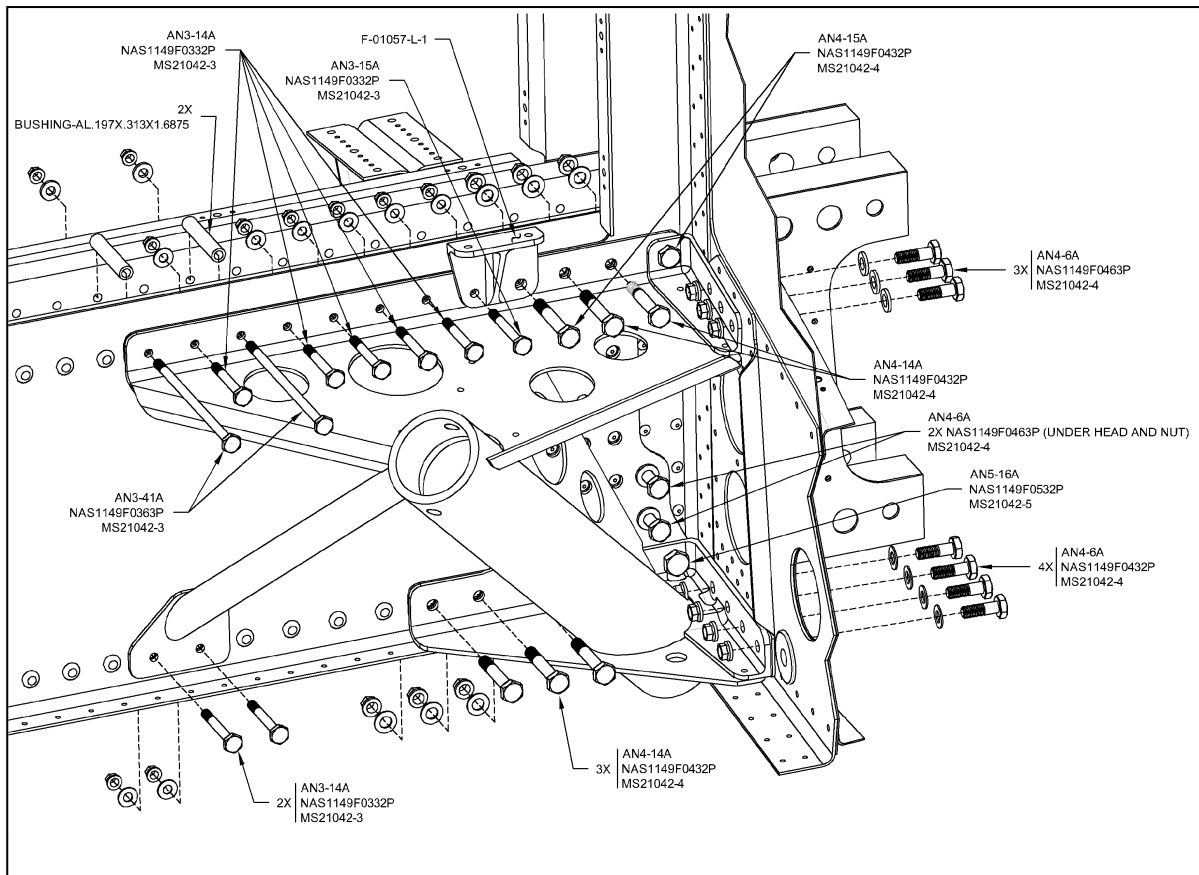

FIGURE 12: INSTALLING THE GEAR LEG WELDMENT

Step 42: Stop drill any visible cracks in the F-1050 Forward Cabin Floor Panels where the forward member of the original gear weldment attached. (Deformation of the understructure is acceptable since the new weldment does not attach in this location.)

Step 43: If desired, a patch of .025 thick aluminum can be formed and riveted in place to cover the hole in the floor.

Step 44: Install the main gear legs in the WD-1021-L/R-1 Landing Gear Mounts as detailed on KAI Page 46-04, Steps 1-4.

Step 45: Install the main wheels on the U-1001 Main Gear Legs as directed in Section 46.

Step 46: Reinstall the bulkhead fluid fitting in the WD-1021-L/R-1 Landing Gear Mounts and reattach the brake lines. See KAI Page 36-2, Figures 1 and 2.

Step 47: Refill, bleed, and test the brake system.

Step 48: Install the top engine cowl.

NOTE: Review and complete SL-00003 before reattaching the wings.

Step 49: Attach the wings according to KAI Section 44.

Step 50: Connect the F-1064 Aileron Pushrod Assembly to the WD-1014 Torque Tube Assembly and connect the VA-256 Flap Pushrod Assembly to the WD-1013B Flap Horn. See KAI Section 44.

Step 51: Jack the aircraft using the wing jacking points, remove the sawhorse from under the fuselage, then carefully lower the aircraft onto the landing gear.

Step 52: Connect the fuel supply lines to the fuel tank (KAI Section 44), and connect the wiring and pitot line (KAI Section 20).

Step 53: Reinstall the F-1099A & B Upper and Lower Wing Root Fairings and the W-1015 Wing Tips. See KAI Sections 24 and 44.

Step 54: Reinstall the U-1057A & B Wheel Fairings, U-1020 Upper Intersection Fairings, and U-1017A Gear Leg Fairings. See KAI Section 48.

Step 55: Reinstall the WD-1012 Control Sticks. See KAI Section 39.

Step 56: For the nutplates shown in Figure 13, use a nutplate as a drill guide to match-drill #40 the nutplates attach rivet holes into the F-1067A Seat Floor. (Only the nutplates for the outboard seat rails are installed; the installation of the inboard seat rails is unchanged.) Machine countersink the seat floor for the nutplate attach rivets, then install the nutplates.

Step 57: Install the F-1067A Seat Floor and the F-1015D-L/R Mid Cabin Side Covers. See KAI Section 35.

Step 58: Match-Drill #19 the F-01057-L/R-1 Mid Seat Rail Supports from the two indicated holes in the F-1067A Seat Floors. See Figure 13. Clean out any drill chips/shavings.

Step 59: Install the seat rails using the hardware called out in Figure 13 and on KAI Page 49-03, Figure 2.

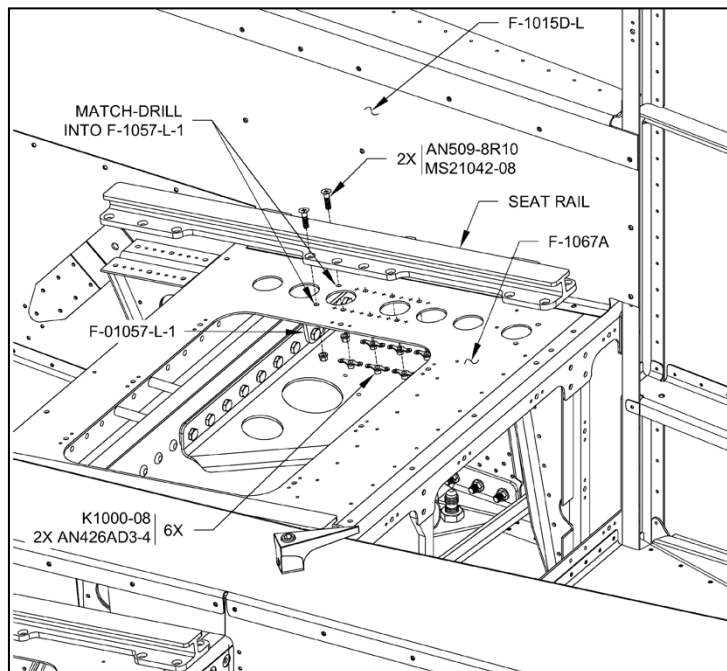

FIGURE 13: INSTALLING SEAT FLOOR NUTPLATES

Step 60: Install the F-1043D (or F-01043D-1 if purchased) Cover Panels and F-1067B Seat Floor Covers. See KAI Sections 28 and 35.

Step 61: Install the front seats. See KAI Section 49.

Step 62: Update the weight and balance for an additional 2.9 lbs. at 112.52 inches.

Step 63: Make a logbook entry indicating compliance with SB-00007 per the requirements of the controlling authority.

If you are no longer in possession of this aircraft, please forward this information to the present owner/operator and notify Van's Aircraft, Inc.

Contact:

<https://www.vansaircraft.com/qr/transfer-of-ownership/>